



TH/15 Emergency Escape Breathing Device

Instructions



SHANGHAI FANGZHAN FIRE TECHNOLOGY CO., LTD.

Instructions

TH/15 Emergency Escape Breathing Device (Hereinafter referred to as EEBD) is a self-protective breathing apparatus for people in distress to escape and self-protect. Only operated properly can it help users escape from accident spot safely within effective use of time.

Life is precious. Please prepare escape devices in your work environment and know their functions and instructions.

Warnings!

- 1、 This product is for escape only, not for entering or returning to environment unable to breathe;**
- 2、 This product is not for escape from water;**
- 3、 This product is for trained adults of physical fitness only**
- 4、 始终确保逃生路线需要的时间应小于本产品持续工作时间。**

Contents

I 、 Summary.....	4
1.1 Main purposes.....	4
1.2 Applied environments.....	4
1.3 Implementation standards.....	4
1.4 Features.....	4
1.5 Main performance indicators.....	4
II 、 Device structures.....	5
III、 Wearing diagrams.....	5
IV、 Inspections and maintenances.....	7
4.1 Daily inspections.....	7
4.2 Daily maintenances.....	8
4.3 Notes.....	8
V 、 Fault identifications and solutions.....	9
VI、 Device integrity.....	10
VII、 Transport and storage.....	10
7.1 Transport.....	10
7.2 Storage.....	10
VIII、 Maintenances.....	10
8.1 Product warranty.....	10
8.2 Maintenances.....	10
IX、 Certificates.....	11

I 、 Summary

1.1 Main purposes

TH/15 Emergency Escape Breathing Device is a self-contained compressed air breathing apparatus, mainly used for emergency escape from the environment that can not breathe.

1.2 Applied environments

1.2.1. Environment of Smoke, hypoxia, as well as environment polluted by toxic gas, smoke, steam, etc.

1.2.2. Environment of temperature of $-30^{\circ}\text{C} \sim 60^{\circ}\text{C}$, relative humidity of $0 \sim 100\%$, atmospheric pressure of $0.7\text{bar} \sim 1.25\text{bar}$.

1.3 Implementation standards

This product, after tested, meets the ISO 23269-1:2008 standards, the EU Marine Equipment Directive (MED)96/98 EC requirements, the 2000 amendments to the 1974 SOLAS Convention Chapter 11-2 / 13.3.4 and the International Fire Safety Systems (FSS) rules Chapter 3 2.2.

1.4 Features

1.4.1. Abiding by the International Maritime Organization (IMO) requirements, this product's continuous use time is longer than 15 minutes, and it's with light weight, easy to operate, and without complicated operations. Just wear the mask to protect the wearer.

1.5 Main performance indicators

Table 1

Cylinder volume	3.0L
Inflation pressure	$210\text{bar} \pm 10\text{bar}$
Duration	$\geq 15\text{min}$
Amount of air released	$\geq 600\text{L}$
Equipment(including gas) weight	$\leq 7.5\text{kg}$

II、 Device structures

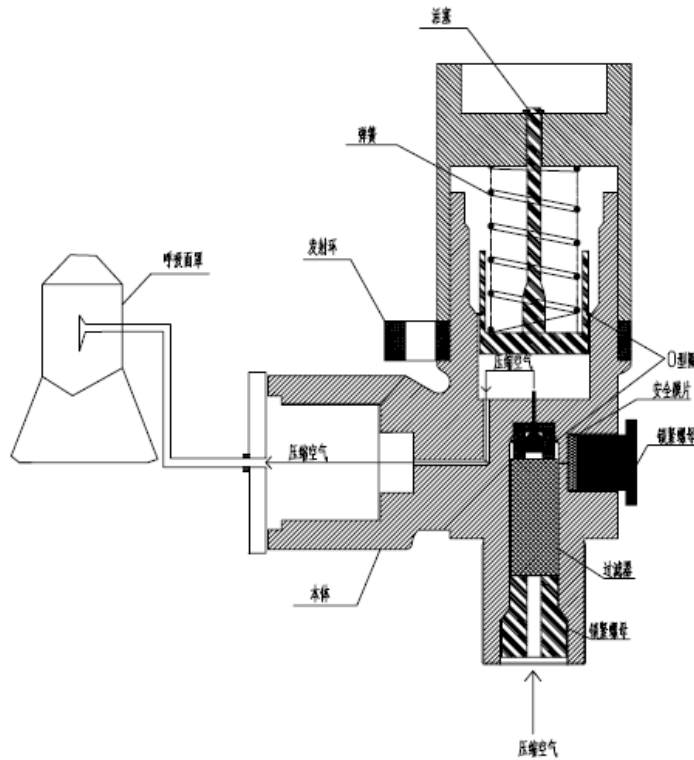

Open the launch belt, and under the action of the spring force, the lifting rod resulting in displacement, corresponding to promote the control of body movement. At this point, cylinder valve is open, compressed air, through the water sealing cap (quantitative hole), enters the filter for decompression, then through the medium-pressure pipe, nose and mouth cover, flows into the mask for the wearer to use.

III、 Wearing diagram



1. Check the pressure gauge, observe the cylinder capacity and tear the seal.



2. Put on the satchel, pull out launch belt to open it



3. Take out the face mask and wear it from the head down, and be noticed that transparent window is in the front and the shawl covers the shoulders.



4. Escape from the accident spot quickly.

IV、 Inspections and maintenances

Escape device, as daily backup, should be inspected at least once a quarter.

4.1 Daily inspections

4.1.1 Check the integrity of various components and see if there is damage;

4.1.2 Observe pressure gauge reading, and make sure the air pressure inside the cylinder should be no lower than 210bar(20 °C). Once lower than 210bar, supply air, but not exceed the specified number.

※Note: As a result of expansion and contraction of the compressed air, the pressure inside the cylinder varies according to temperature. It's normal for low pressure caused by temperature too low and high pressure by temperature too high. For room temperature 20 °C , the air pressure inside is 210 bar. Temperature and pressure correlation, please refer to

table 2(approximate number for reference only)

Table 2

Temperature	Air pressure inside (bar)	Temperature	Air pressure inside(bar)
-30°C	160	20°C	210
-20°C	170	30°C	220
-10°C	180	40°C	230
0°C	190	50°C	240
10°C	200	60°C	250

4.2 Daily maintenances

4.2.1 Cylinder

a. Avoid collision, scratch and pound; avoid high-temperature baking, freezing, and sun exposure; repair peeling paint and prevent sidewall rust;

b. Use it according to date marked; do pressure test once every three years and be qualified before use;

c. Inflate timely after use for next use;

4.2.2 Decompression device

Do not disassembly during use. Once repairing, re-adjust the chamber pressure and flow.

4.3 Notes

(1)The device should be placed in a dry, clear, easy-to-access place where there is no direct sunlight;

(2) The device should not come close to any grease or other corrosive liquid;

(3) The cylinder should do pressure test once every three years in manufacturer or government authority and be qualified before use;

(4) The device should avoid heavy pressing, high-temperature baking, freezing and sun exposure;

(5) Train relevant personnel before using the device;

(6) Once there is failure or damaged parts, repair them in manufacturer or its authorized agencies;

- (7) No filling oxygen to the cylinder to avoid accidents;
- (8) Inflate the cylinder to 210 bar first and after cooling, re-inflate to 210 bar to ensure use time;
- (9) Compressed air for breathing should be clean, free of odor and meet the following requirements:
 - CO no more than 5.5mg/m³
 - CO₂ no more than 900mg/m³
 - Oil no more than 0.5mg/m³
 - Water no more than 50mg/m³
- (10) The device should not be used for fire fighting, into an hypoxia empty tank or liquid cargo, or for fire fighters;
- (11) No wear the face mask before opening the cylinder valve; Once inspecting the mask, separate the mask from connection chain; connect them after inspection;

V、Fault identification and solution

Table 3

Faults	Causes	Solutions
Cylinder valve leakage	Valve disc rupture, pressure cap screw loose, O-ring aging	Replace disc, tighten pressure cap, replace O-ring
Pressure gauge no reading	Gauge damage, leakage, air hose block or leakage	Replace gauge or air hose
Connection parts leakage	O-ring damage or aging	Replace O-ring
Mask, bag damages	Aging or damaged	Replace mask, bag

VI、 Integrity of the device

Complete sets include:

1 Escape device	one set
2 Device bag	one piece
3 Device packing carton	one piece
4 Files with the device	one set

VII、 Transport and storage

7.1 Transport

No rain exposure, no putting in one carriage with oil, flammable, corrosive media, and handle it gently;

7.2 Storage

Place the device in dry, clear, easy-to-access place where the relative humidity is less than 80%, away from the heat by not less than 1.5m; and avoid sun exposure;

VIII、 Maintenance

8.1 Product warranty

The escape device(EEBD) is within warranty six months from leaving the factory; if exceeding six months, the maintenance is by the user; users should do the repair in the manufacturer or authority approved repair station;

8.2 Maintenance

User should, according to related agencies' requirements, check the escape device(EEBD) periodically, establish record card; if any problems occur, solve them in time. Please refer to chapter V-- Fault identification and solutions. When replacing pressure gauge, do the following:

- a. Open EEBD cylinder valve, clear the air inside;
- b. Use a wrench to remove the pressure gauge;
- c. Replace a new one, and tighten it;
- d. Use air compressor or charging unit (pressure should be greater than 210 bar) to inflate the cylinder to 210bar (20 °C) first and after

cooling, re-inflate to 210 bar to ensure use time;

e. Check the cylinder into water to check tightness;

f. Connected the qualified cylinder with medium-pressure air hose and put EEBD into the bag;

IX、Certificates

1. MED Type Approval Certificate

SHANGHAI FANGZHAN FIRE TECHNOLOGY CO., LTD.

No.288 Jianzhong Road, Laogang Town, Pudong NewArea,Shanghai City

TEL: +86-21-68150888

FAX: +86-21-68151883

E-MAIL: fzxf119@126.com

WEBSITE: www.119fz.com

KR HELLAS LTD.
41, Athinas Av., Vouliagmeni,
GR-16671, Athens, Greece
TEL: +30-210-428-6736
FAX: +30-210-428-6728



KR HELLAS

Certificate No:
MED- MB-3004-11
MED Item No: A.1/3.41
This consists of 3 pages.
Page 1/3

EC TYPE EXAMINATION CERTIFICATE

as per **Module B**

of European Council Directive 96/98/EC on Marine Equipment (MED)

THIS IS TO CERTIFY that KR Hellas Ltd., designated by the Hellenic Republic of Greece as Notified Body according to Council Directive 96/98/EC on Marine Equipment as amended, did undertake the EC Type Examination procedures for the product identified below according to the following specific standards and that the product is found to meet the specific standards in compliance with the requirements of Annex A.1, Section 1, item No. A.1/3.41 and Annex B, Module B in the Council Directive 96/98/EC as amended by Commission Directive 2009/26/EC:

Manufacturer Name : Shanghai Fangzhan Fire Technology Co., Ltd.
Address : No.288, Gangnan YiZu, Laogang Town, Pudong New Area, Shanghai, China
Product Name (A.1 item designation) : Emergency escape breathing devices (EEBD)
Product Type : TH/15
Specific Standards : SOLAS 1974 as amended, Reg. II-2/13 and IMO Res. MSC.98(73)-(FSS code) 3 and IMO MSC/Circ.849, EN 1146(2005) and ISO 23269-1(2008)

This certificate is issued at Athens on 17th March 2011, under the authority of the Hellenic Republic of Greece by KR Hellas Ltd., Notified Body No. 2198.

This certificate is valid until 16th March 2016.

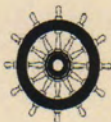

Notified Body No.2198



Kwon Jae-Geun

CEO of KR Hellas Ltd.

Any person not a party to the contract pursuant which this document is delivered may not assert a claim against KRH for any liability arising out of errors or omissions which may be contained in said document, or for errors of judgment, fault or negligence committed by personal of KRH in establishment or issuance of this document, and in connection with any activities for which it may provide. In this provision KRH shall mean the KR Hellas Ltd. as well as all its subsidiaries, directors, officers, employees and any other acting on behalf of KR Hellas Ltd.